

Installation/dismantling

Series 498/598

Flange connection with Hirth-serration

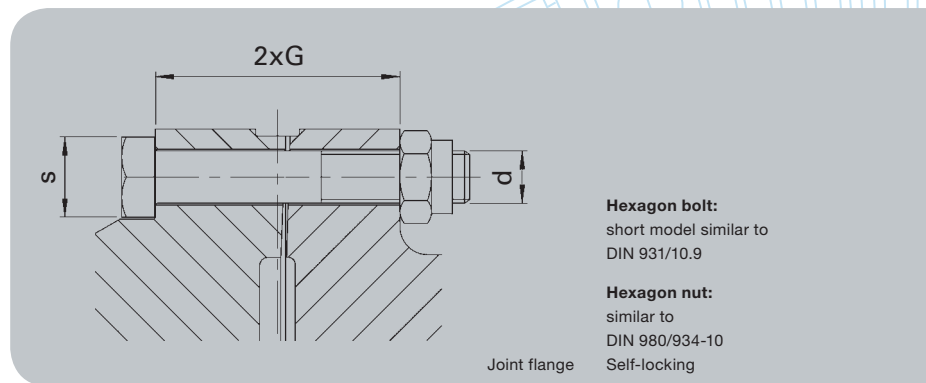

Series 498/598

Shaft size		498.00 598.00	498.05 598.05	498.10 598.10	498.15 598.15	498.20 598.20	498.25 598.25	498.30 598.30	498.35 598.35	498.40 598.40	498.45 598.45	498.50 598.50	498.55 598.55	498.60 598.60
Flange dia.	mm	600	650	700	750	800	850	900	950	1.000	1.050	1.100	1.150	1.200
Ta	Nm	900	900	900	1.800	1.800	3.150	3.150	3.150	5.400	5.400	5.400	8.200	8.200
d	–	M 24	M 24	M 24	M 30	M 30	M 36	M 36	M 36	M 42 x 3	M 42 x 3	M 42 x 3	M 48 x 3	M 48 x 3
s	mm	36	36	36	46	46	55	55	55	65	65	65	75	75
i ¹⁾	–	20	20	24	24	24	24	24	24	20	20	20	20	20
Bolts inserted from joint side		no	no	no	no	no	no	no	no	no	no	no	no	no

1) = Number of bolt holes

Ta = Tightening torque of bolting Special torque wrenches supplied on request

