

Installation/dismantling

Series 492

Flange connection with Hirth-serration

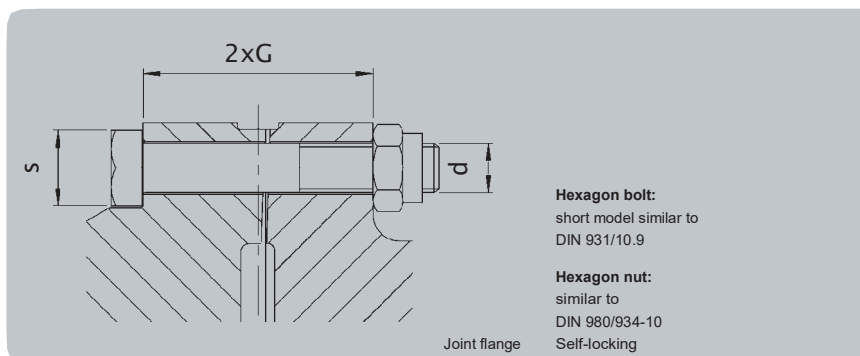

Series 492

Shaft size		492.60	492.65	492.70	492.75	492.80	492.85	492.90
Flange dia.	mm	285	315	350	390	435	480	550
Ta	Nm	175	270	270	375	375	525	720
d	-	M 14	M 16	M 16	M 18	M 18	M 20	M 22
s	mm	21	24	24	27	27	30	32
i ¹⁾	-	10	10	12	12	16	16	16
Bolts inserted from joint side		no	no	no	no	no	no	no

1) = Number of bolt holes

Ta = Tightening torque of bolting Special torque wrenches supplied on request