

Data sheet series 390 Maximum bearing life

0.01 with length compensation, tubular design
 0.02 with large length compensation, tubular design
 0.03 without length compensation, tubular design

9.01 with length compensation, short design
 9.02 with length compensation, short design
 9.03 with length compensation, short design
 9.04 without length compensation, double flange shaft design

Design

0.01

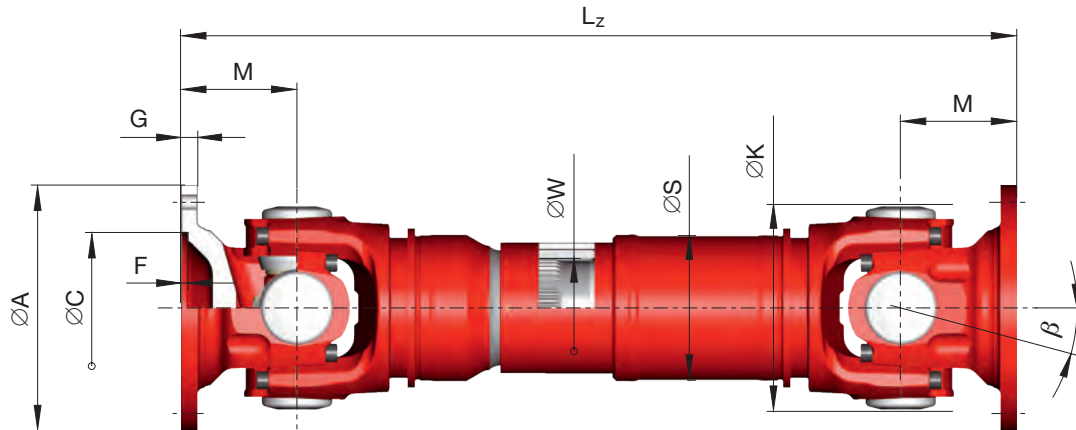

Shaft size		390.60	390.65	390.70	390.75	390.80
T _{Cs}	kNm	60	90	130	190	255
T _{DW}	kNm	23	36	53	75	102
L _c	-	25	72	243	627	1.583
β	°	15	15	15	15	15
A	mm	285	315	350	390	435
K	mm	240	265	300	330	370
B ± 0,1 mm	mm	245	280	310	345	385
Bs ± 0,1 mm	mm	240	270	300	340	378
C H7	mm	175	175	220	250	280
F ¹⁾	mm	6	6	7	7	9
G	mm	20	22	25	28	32
H ⁴⁾	mm	20,1	22,1	22,1	24,1	27,1
Hs H12	mm	28	30	32	32	35
I ²⁾	-	8	8	10	10	10
Is ³⁾	-	4	4	4	4	4
M	mm	135	150	170	190	210
S	mm	167,7 x 9,8	218,2 x 8,7	219 x 13,3	273 x 11,6	273 x 19
W DIN 5480	mm	120 x 2,5	150 x 3	150 x 3	185 x 5	185 x 5

T_{Cs} = Functional limit torque*
 If the permissible functional limit torque T_{Cs} is to be fully utilized, the flange connection (e.g., with dowel pins) must be reinforced. Yield torque 30% over T_{Cs}

T_{DW} = Reversing fatigue torque*
L_c = Bearing capacity factor*
 * See specifications of driveshafts.
 β = Maximum deflection angle per joint

1) Effective spigot depth
 2) Number of flange holes (standard flange connection)
 3) Number of flange holes (dowel pin connection)
 4) 390.60 - 390.70 + 0,2 mm
 390.75 - 390.80 + 0,5 mm

Data sheet series 390 Maximum bearing life

Design

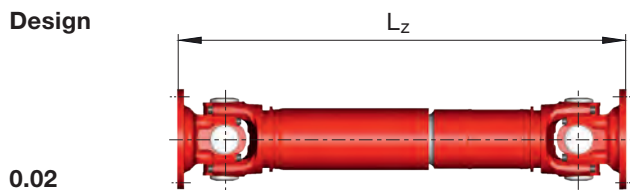

0.02

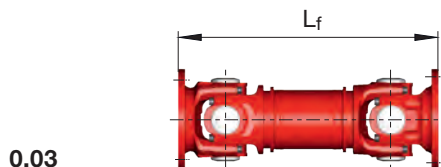

0.03

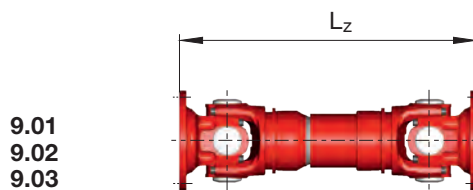

9.01
9.02
9.03

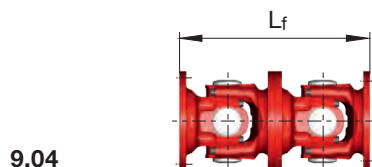

9.04

Standard flange connection

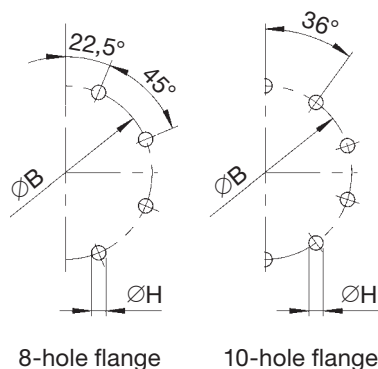

8-hole flange

10-hole flange

Dowel pin connection according to DIN 15451

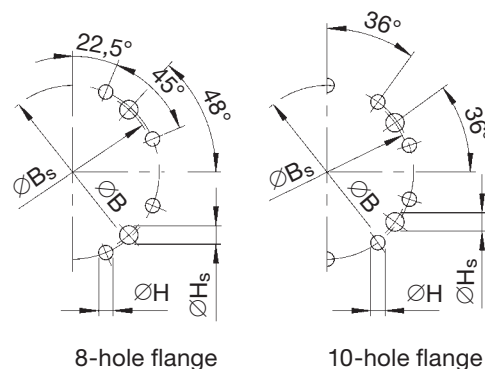

8-hole flange

10-hole flange

NOTE: Each driveshaft size has a specific hole pattern (see table). Other hole patterns available on request.

Design	Shaft size	390.60		390.65	390.70	390.75	390.80	
0.01	$L_{z \min}$	mm	870	964	980	1.070	1.210	1.280
	L_a	mm	110	140	135	135	170	170
	G	kg	151	157	216	276	405	490
	G_R	kg	38,2	38,2	44,9	67,5	74,8	119,0
	J_m	kgm ²	1,04	1,05	1,61	2,51	4,2	8,2
	J_{mR}	kgm ²	0,239	0,239	0,494	0,717	1,28	1,93
	C	Nm/rad.	$1,08 \times 10^6$	$1,08 \times 10^6$	$1,65 \times 10^6$	$2,43 \times 10^6$	$3,3 \times 10^6$	$4,7 \times 10^6$
	C_R	Nm/rad.	$2,43 \times 10^6$	$2,43 \times 10^6$	$5,04 \times 10^6$	$7,3 \times 10^6$	$1,3 \times 10^7$	$1,97 \times 10^7$
0.02*	$L_{z \min}$	mm	1.210	1.360	1.450	1.450	1.640	
	$L_{a \min}$	mm	300	300	300	300	300	
	G	kg	189	300	361	530	690	
	G_R	kg	38,2	44,9	67,5	74,8	119,0	
0.03	$L_{f \min}$	mm	640	710	800	890	960	
	G	kg	109	159	218	302	385	
	G_R	kg	38,2	44,9	67,5	74,8	119,0	
9.01	L_z	mm	843	953	1.043	1.175	1.245	
	L_a	mm	100	135	135	170	170	
	G	kg	136	213	273	402	482	
9.02	L_z	mm	810	890	980	1.100	1.170	
	L_a	mm	70	75	75	95	95	
	G	kg	135	198	261	375	456	
9.03	L_z	mm	750	835	925	1.030	1.100	
	L_a	mm	65	75	75	85	85	
	G	kg	135	202	264	371	453	
9.04	L_f	mm	540	600	680	760	840	
	G	kg	108	146	210	284	380	

$L_{z \min}$ = Shortest possible compressed length

L_a = Length compensation

$L_{f \min}$ = Shortest fixed length

$L_z + L_a$ = Maximum operating length

G = Weight of shaft

G_R = Weight per 1.000 mm tube

J_m = Moment of inertia

J_{mR} = Moment of inertia per 1.000 mm tube

C = Torsional stiffness of shaft without tube

C_R = Torsional stiffness per 1.000 mm tube

* Larger length compensation available on request