

Installation/dismantling

Series 390 Standard bolting

Shaft size		390.60	390.65	390.70	390.75	390.80
Flange dia.	mm	285	315	350	390	435
Ta	Nm	580	780	780	1.000	1.500
c	mm	202	230	256	295	332
c ₁	mm	214	247	277	308	343
d	-	M 20	M 22	M 22	M 24	M 27
l	mm	64	70	75	85	95
v	mm	24	26	25	29	31
s	mm	30	32	32	36	41
i ¹⁾	-	8	8	10	10	10
Bolts inserted from joint side		yes	yes	yes	yes	yes

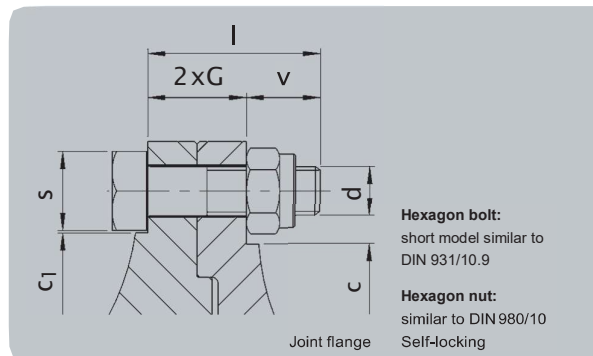

Series 390 Dowel pin connection

Shaft size		390.60	390.65	390.70	390.75	390.80
Flange dia.	mm	285	315	350	390	435
Ta	Nm	200	200	280	280	400
c	mm	202	230	256	295	332
c ₁ ²⁾	mm	198	228	254	294	332
d	-	M16	M16	M18	M18	M20
l	mm	75	75	90	95	110
d _s	mm	28	30	32	32	35
l _s	mm	36	40	45	50	60
v	mm	23	19	24	23	30
a	mm	6	6	8	8	8
s	Nm	24	24	27	27	30
i ¹⁾	-	4	4	4	4	4
Bolts inserted from joint side		yes	yes	yes	yes	yes

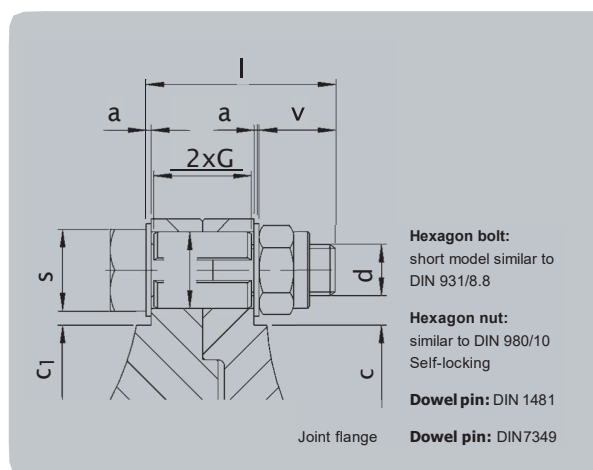

1) = Number of bolt holes

2) = Dowel pin connection without locking

Ta = Tightening torque of bolting Special torque wrenches supplied on request